

WDMPsc Overview

HST GuardianBlue System

Service Training

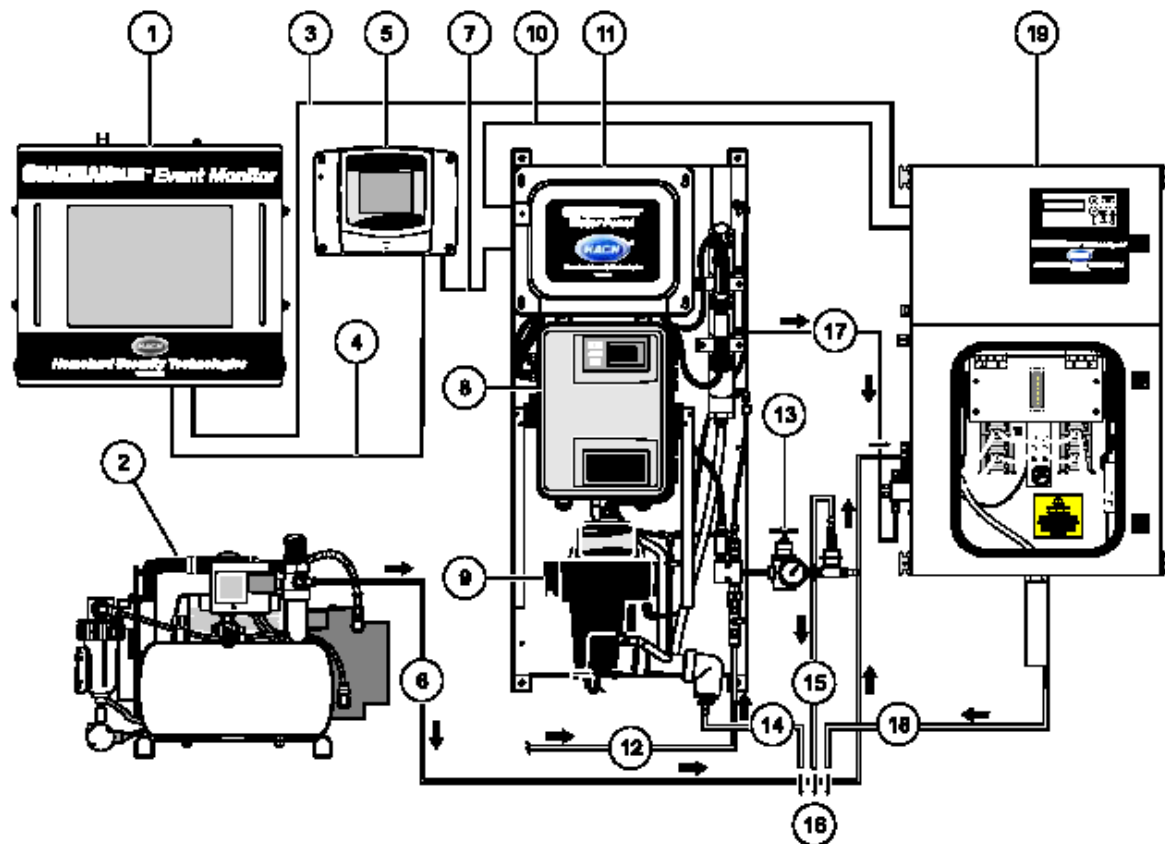

Figure 1 GuardianBlue Early Warning System overview

1	Event Monitor	8	CL17 chlorine analyzer	15	Sample drain
2	Purge gas generator (for TOC)	9	1720E turbidimeter	16	To approved drain
3	Event Monitor to TOC analyzer	10	TOC to Water Panel communication	17	TOC sample from Water Panel
4	Event Monitor to sc1000 controller	11	Water Panel	18	TOC analyzer drain
5	sc1000 controller	12	Sample in	19	TOC analyzer
6	Purge gas generator to TOC analyzer	13	Pressure regulator (allows sample hookup to external autosampler)		
7	sc1000 controller to Water Panel communication	14	Water Panel drain		

WDMPsc Overview

- Instruments
- Electronics
- Plumbing
- Connections to TOC
- Connection to Sampler
- sc1000

WDMPsc Instruments

- CL17 – Analog
- 1720e – Digital
- DpHD – Digital
- 3400 Series Contacting Conductivity – Digital
- GEMS Pressure sensor - Analog

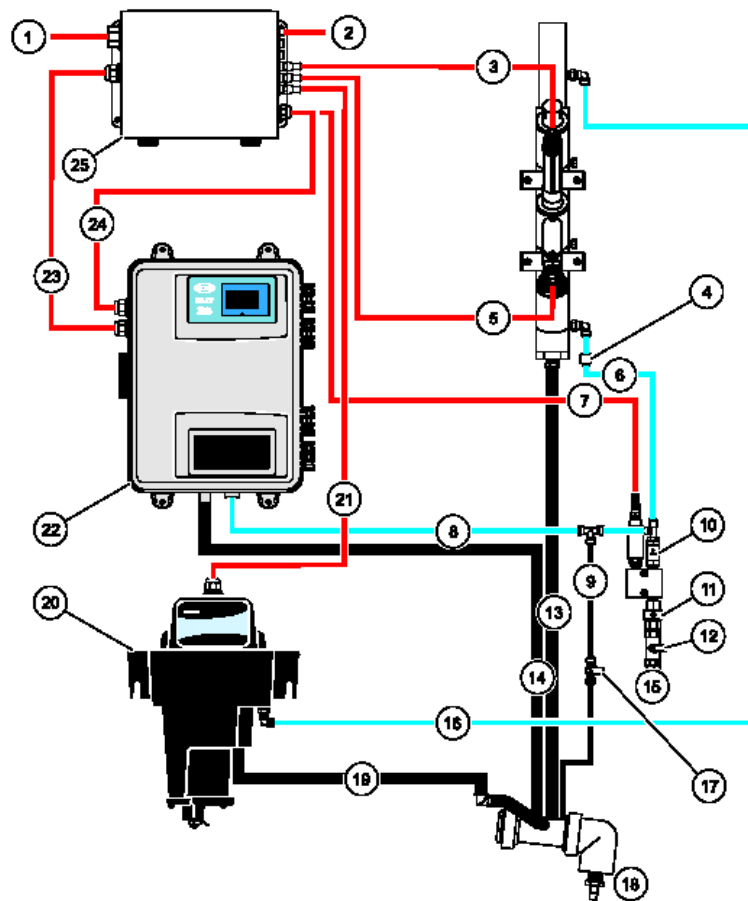

Figure 111 Fluid flow and electrical diagram

1 AC power in	10 Flow regulator	19 1720E drain
2 To sc1000 controller	11 One-way flow valve (prevents back-flow)	20 1720E turbidimeter
3 pH probe	12 Shut-off valve	21 Digital signal from 1720E
4 Flow-restrictor assembly	13 Manifold drain	22 CL17 chlorine analyzer
5 Conductivity probe	14 CL17 drain	23 AC power to CL17
6 Sample to manifold	15 Sample in	24 Analog signal from CL17
7 Gems Pressure Sensor	16 Sample to 1720E	25 Signal junction box
8 Sample to CL17	17 Shut-off valve	
9 Manifold drain	18 To drain	

WDMPsc Electronics

- Junction Box houses Power supply and Gateways
- All instruments are powered by the WDMPsc junction box NOT the sc1000
- Gateways are the same – difference between Chlorine and Pressure is just programming
- CL17 and Pressure sensor are connected differently

WDMPsc Communication Connections

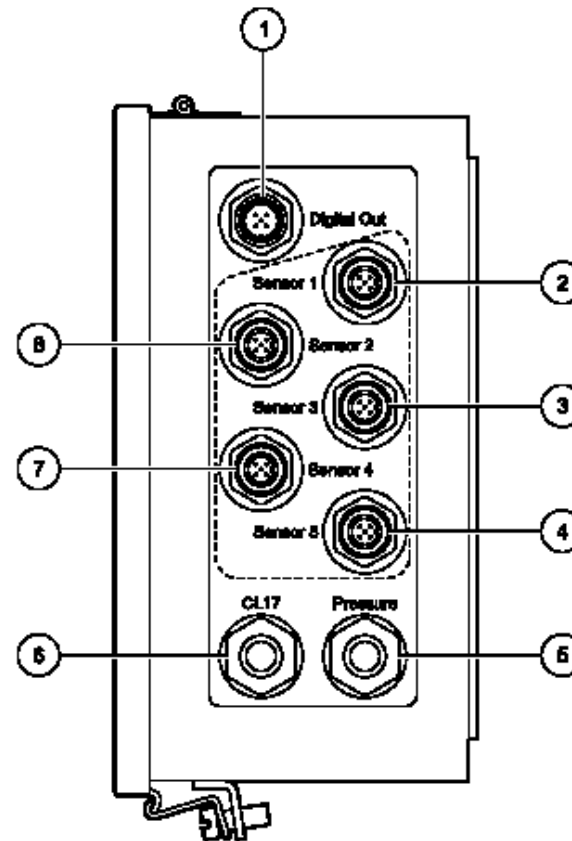

Figure 45 Water panel junction box instrument connections

1	To sc1000 controller	5	4–20mA Gems pressure sensor connector
2	1720E connector	6	4–20mA CL17 connector
3	TOC analyzer connector	7	pH sensor connector
4	Optional ORP sensor connector	8	Conductivity sensor connector

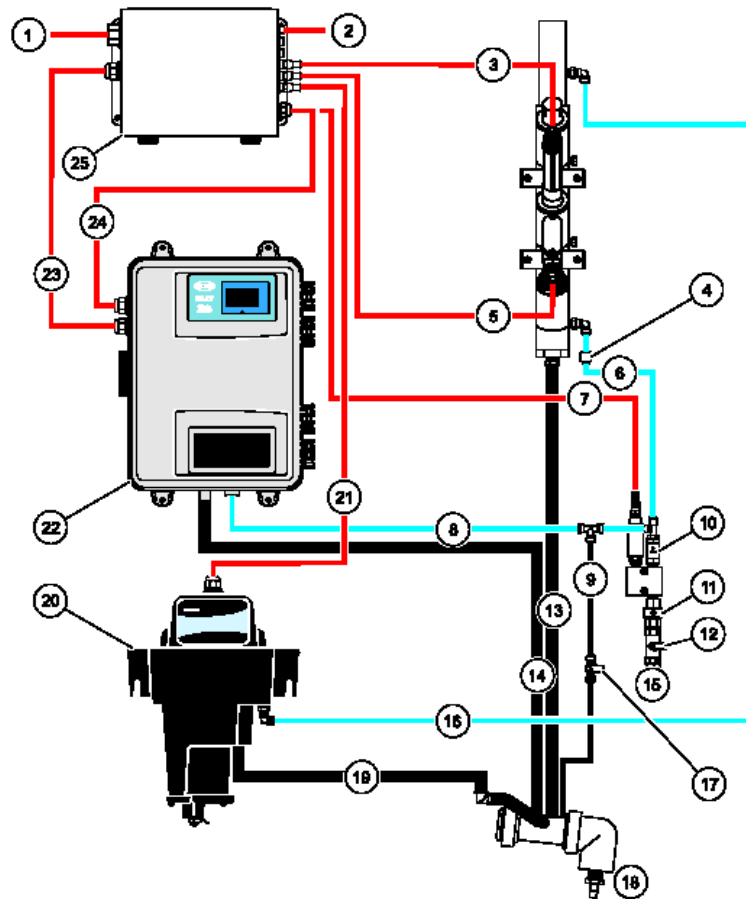

Figure 111 Fluid flow and electrical diagram

1 AC power in	10 Flow regulator	19 1720E drain
2 To sc1000 controller	11 One-way flow valve (prevents back-flow)	20 1720E turbidimeter
3 pH probe	12 Shut-off valve	21 Digital signal from 1720E
4 Flow-restrictor assembly	13 Manifold drain	22 CL17 chlorine analyzer
5 Conductivity probe	14 CL17 drain	23 AC power to CL17
6 Sample to manifold	15 Sample in	24 Analog signal from CL17
7 Gems Pressure Sensor	16 Sample to 1720E	25 Signal junction box
8 Sample to CL17	17 Shut-off valve	
9 Manifold drain	18 To drain	

WDMPsc Plumbing

- Panel can take sample directly with pressures between 20 and 100 psig
- Panel has constant flow device – limits flow to about 500 ml/min
- Constant flow device and fixed orifice flow restrictor on sample manifold are smallest orifices on panel
- Flow path – all sample that goes through sensor manifold should go to turb
- Draining the sensor manifold – shut sample valve off, open ¼" drain valve

TOC/WDMP Sample Connection

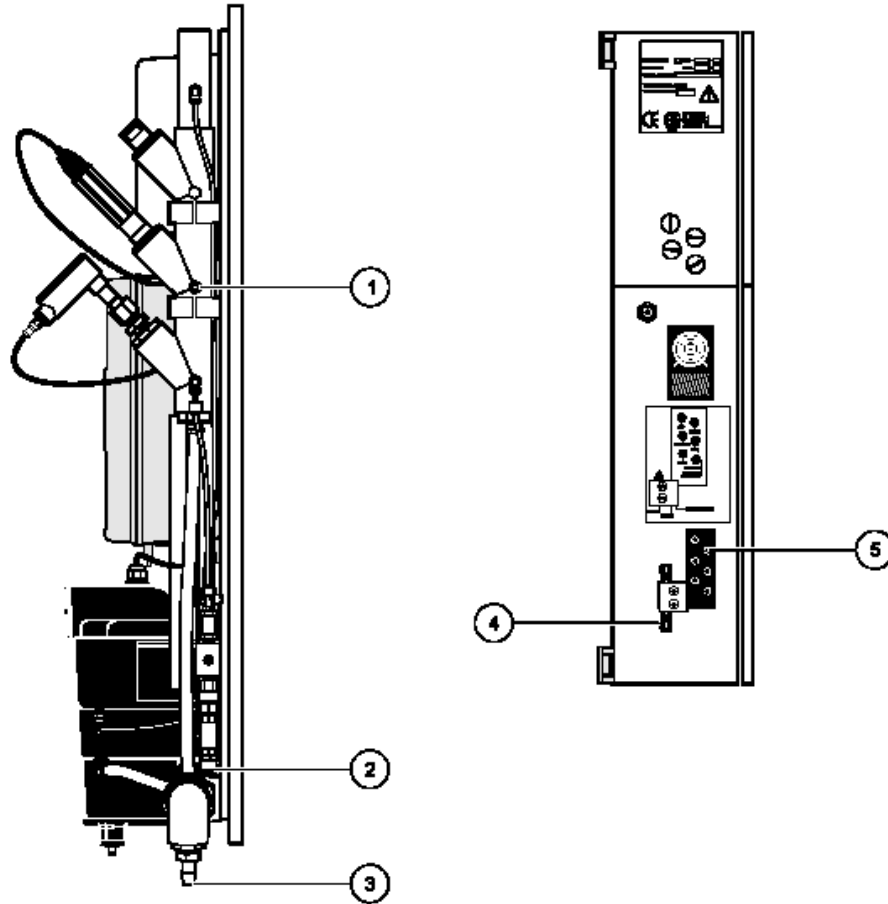
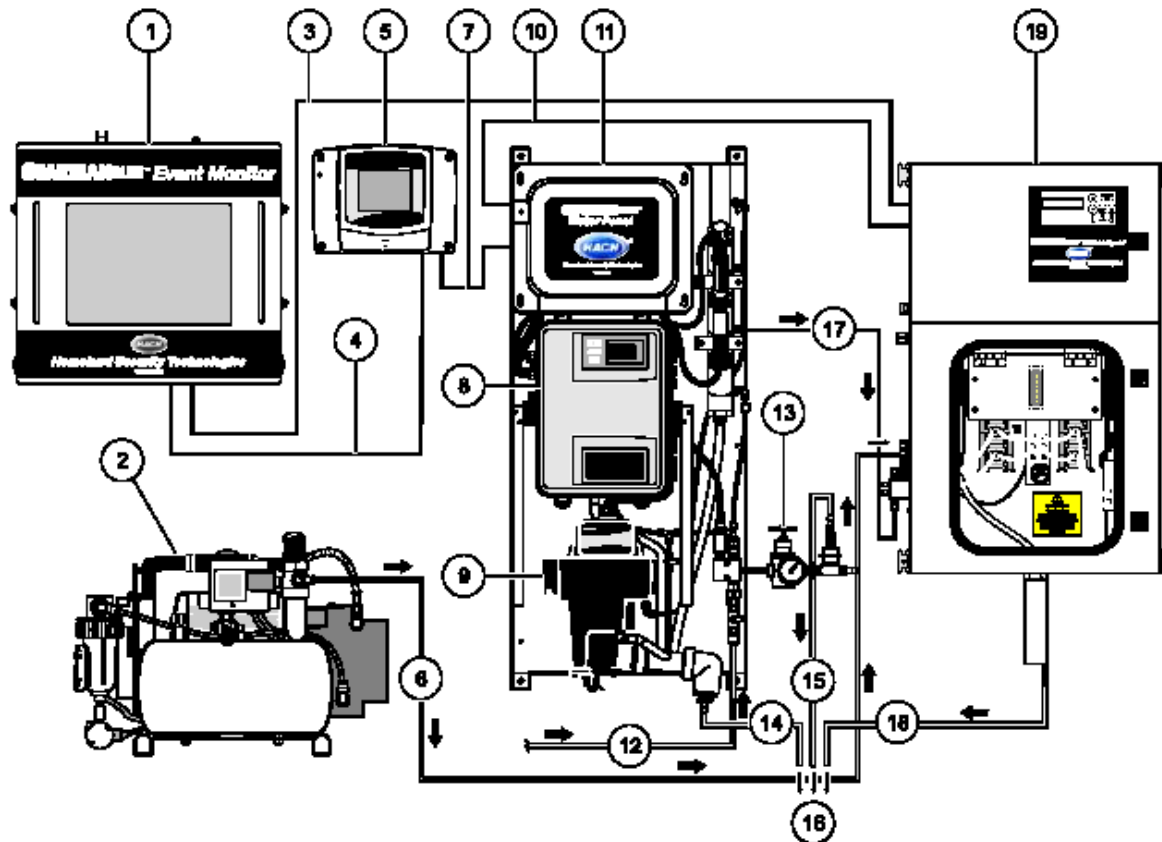

Figure 46 Water panel to TOC analyzer connection

1 TOC sample connection	4 Water Panel connection on sample input block
2 Sample inlet	5 Purge gas generator connection
3 Drain manifold	



Sampler
connection
to WDMPsc

Figure 1 GuardianBlue Early Warning System overview

1	Event Monitor	8	CL17 chlorine analyzer	15	Sample drain
2	Purge gas generator (for TOC)	9	1720E turbidimeter	16	To approved drain
3	Event Monitor to TOC analyzer	10	TOC to Water Panel communication	17	TOC sample from Water Panel
4	Event Monitor to sc1000 controller	11	Water Panel	18	TOC analyzer drain
5	sc1000 controller	12	Sample in	19	TOC analyzer
6	Purge gas generator to TOC analyzer	13	Pressure regulator (allows sample hookup to external autosampler)		
7	sc1000 controller to Water Panel communication	14	Water Panel drain		

Sc1000 for WDMPSc

- Has 2 Analog OUT cards (total of 8 outputs)
- Has 1 ModBUS rs485 card (used to communicate with the EM)
- Has room for relay card
- Has 4 digital connectors (customers may only connect sc1000 to GuardianBlue water panel)
- Telegram should be set up in a particular order to work with default EM sc1000 configuration

Default sc1000 Telegram setup

1720E	
0	Error
1	Status1
2	Turbidity
PhD sc	
4	Error
5	Status1
6	pH
8	Temperature
34xx sc Conductivity	
10	Error
11	Status1
12	Conductivity
14	Temperature
sc input gateway CHLORINE	
16	Error
17	Status1
18	measure
20	current
sc input gateway PRESSURE	
22	Error
23	Status1
24	measure
26	current
sc input gateway TOC	
28	Error
29	Status1
30	measure
32	current